

TABLE OF CONTENTS

| | |
|---|-----------|
| 1. PRODUCT WARRANTY..... | 3 |
| 2. CHECKLISTS Dealer's File Copy..... | 4 |
| Customer's File Copy..... | 5 |
| 3. INTRODUCTION..... | 6 |
| 4. SPECIFICATIONS..... | 7 |
| 5. SAFETY..... | 8 |
| 5.1 Mandatory Safety Shutdown Procedure..... | 9-10 |
| 6. OPERATION..... | 11 |
| 6.1 Forward..... | 11 |
| 6.2 Attaching to and detaching from skidsteer loader..... | 11 |
| 6.3 Preparing to Cut..... | 12 |
| 6.4 Starting the Cut..... | 12 |
| 6.5 Advancing the Cut..... | 12 |
| 6.6 Ending the Cut..... | 13 |
| 7. DAILY MAINTENANCE..... | 13 |
| 7.1 Pic Removal and Replacement..... | 14 |
| 7.2 Removal..... | 14 |
| 7.3 Replacement..... | 15 |
| 7.4 Changing a Wheel..... | 16 |
| 9. FIGURES and PARTS LISTS | |
| UR Rock Wheel Drawing..... | 18 |
| UR Rock Wheel Parts List..... | 19 |
| 55763UR Manual Hydraulic Schematic Drawing..... | 20 |
| 55763UR Hydraulic Schematic Parts List..... | 21 |
| 56984 3 Line Electric Hydraulic Controls Drawing..... | 22 |
| 56984 3Line Parts List | 23 |
| 56985UR 5 Line Electric Hydraulic Controls Drawing | 24 |
| 56985UR 5 Line Electric Hydraulic Parts List | 25 |
| Rock Wheel Gearbox Drawing Auburn..... | 26 |
| Rock Wheel Gearbox Parts List Auburn..... | 27 |
| Rock Wheel Gearbox Drawing Omni | 28 |
| Rock Wheel Gearbox Parts List Omni | 29 |
| Motor | 30 |

1. PRODUCT WARRANTY



PURPOSE OF POLICY

The policy covers correction of defects in workmanship and/or materials called to the attention of Coneqtec/Universal and is subject to all conditions of the warranty.

STATEMENT OF WARRANTY

Coneqtec/Universal warrants its products for up to one year from the purchase date when correctly used under normal operating conditions. Coneqtec/Universal makes no other warranty expressed or implied.

This warranty shall not apply to any products that have been altered, changed or repaired in any manner whatsoever. Nor shall it apply to any product which has been subject to misuse, negligence or accident.

The exclusive and sole remedy for breach of contract (including breach of any express or implied warranty) shall be limited to repair, modification or replacement at the sole discretion of Coneqtec/Universal, of non-conforming products as aforesaid. Coneqtec/Universal shall not in any event be liable to anyone. Faulty or suspect parts must be returned to Coneqtec/Universal at user's cost.

GENERAL

Coneqtec/Universal reserves the right to make changes or improvements in design or construction of any part without incurring the obligation to install such changes on any unit previously delivered.

WARRANTY PARTS & LABOR PROCEDURES

WARRANTY PARTS & LABOR POLICY

Warranty parts credits will be allowed for the replacement parts that prove in the company's judgment to be defective in material or workmanship on machines sold to the original purchaser. No consideration whatsoever will be made on used, second-hand, altered or rebuilt machinery.

Only genuine Coneqtec/Universal parts will be used in correction of defective products. Any parts used that are not of Coneqtec/Universal origin will not be warranted unless prior Coneqtec/Universal approval has been granted.

Warranty labor will be paid at \$40 per hour based on flat rates established by Coneqtec/Universal; however, no mileage or mileage time will be reimbursed.

Warranty will not be paid if the dealer is not capable of doing the testing that is required by Coneqtec/Universal (this pertains to hydraulic testing and the use of pressure testing equipment) to determine the location or source of the problem.

OWNER RESPONSIBILITY

Every owner is responsible for the machine's proper use and maintenance. Parts that are simply worn out through normal wear and tear, or abused or damaged due to lack of maintenance or adjustment are not subject for warranty consideration.

DEALER RESPONSIBILITY

Coneqtec/Universal requires that the dealership has a service center that is staffed and has the ability to setup and do pre-delivery on all units prior to delivery and to do testing that is required by Coneqtec/Universal in the event that there is a problem with the machine.

It is also required that the dealers instruct the customer on the proper operation and safety procedures.

WARRANTY PROCEDURE

Warranty will not be considered on the following unless it can be proved there is negligence in workmanship or materials.

Wear items such as pics, pic blocks, blades and cutters.

Hoses that have been worn or damaged by use.

PROCEDURE FOR CLAIM

Prior to starting any warranty work please call Coneqtec/Universal for approval and notification of flat rate allowances. All warranty claims must be received within thirty days of warranty repair in order to be a valid warranty claim. Otherwise warranty claim will be denied. A copy of the parts invoices and shop work orders must be submitted with the warranty form, and the form must be filled out completely with all customer and machine information. The warranty/RGA form with parts should then be sent to the designated location stated on form. Coneqtec/Universal will pay only standard Fed Ex or LTL truck freight on warranty items.

All warranty credits will be applied to the dealer's account.

Revised 11/1/01

P.O. BOX 9102 • WICHITA, KS 67277 • (888) 832-3462 • Fax (316) 946-5552

2. CHECKLIST

DEALER'S FILE COPY

2.1 PRE-DELIVERY

After the wheel Saw has been completely set-up and attached to the host machine, the following inspections should be made. Check off each item after prescribed action is taken.

Check that:

- ◆ No parts of the unit have been damaged in shipment. Check for things such as dents and loose or missing parts; correct or replace components as required.
- ◆ All bolts and fasteners are in place and tightly secured.
- ◆ All grease fittings have been properly lubricated; see lubrication information in this manual.
- ◆ All decals are in place and securely attached.
- ◆ The serial number of your unit is recorded in the space provided on this page.
- ◆ Then, test run the unit while checking that all components are operating correctly.

I acknowledge that the procedures were performed on this unit as outlined above.

DEALERSHIP NAME

DEALER REPRESENTATIVE'S NAME

DATE CHECKLIST FILLED OUT

SERIAL NUMBER

2.2 DELIVERY

The following checklist is an important reminder of the valuable information that **MUST** be passed on to the customer at the time the unit is delivered. Check off each item as you explain it to the customer.

- ◆ Give the customer his operators manual. Instruct him to be sure to read and completely understand its contents **BEFORE** operating the unit.
- ◆ Explain and review with him the **SAFETY** information in this manual.
- ◆ Explain that regular cleaning and lubrication are required for proper operation and long life. Review with him the lubrication information in this manual.
- ◆ Explain and review with him the service & maintenance information in this manual.
- ◆ Completely fill out the owner's registration, including the customer's signature, and return it to the manufacturer.

I acknowledge that the above points were reviewed with me at the time of delivery.

CUSTOMER'S SIGNATURE

DATE DELIVERED

2. CHECKLIST

CUSTOMER'S FILE COPY

2.1 PRE-DELIVERY

After the wheel Saw has been completely set-up and attached to the host machine, the following inspections should be made. Check off each item after prescribed action is taken.

Check that:

- ◆ No parts of the unit have been damaged in shipment. Check for things such as dents and loose or missing parts; correct or replace components as required.
- ◆ All bolts and fasteners are in place and tightly secured.
- ◆ All grease fittings have been properly lubricated; see lubrication information in this manual.
- ◆ All decals are in place and securely attached.
- ◆ The serial number of your unit is recorded in the space provided on this page.
- ◆ Then, test run the unit while checking that all components are operating correctly.

I acknowledge that the procedures were performed on this unit as outlined above.

DEALERSHIP NAME

DEALER REPRESENTATIVE'S NAME

DATE CHECKLIST FILLED OUT

SERIAL NUMBER

2.2 DELIVERY

The following checklist is an important reminder of the valuable information that **MUST** be passed on to the customer at the time the unit is delivered. Check off each item as you explain it to the customer.

- ◆ Give the customer his operators manual. Instruct him to be sure to read and completely understand its contents **BEFORE** operating the unit.
- ◆ Explain and review with him the **SAFETY** information in this manual.
- ◆ Explain that regular cleaning and lubrication are required for proper operation and long life. Review with him the lubrication information in this manual.
- ◆ Explain and review with him the service & maintenance information in this manual.
- ◆ Completely fill out the owner's registration, including the customer's signature, and return it to the manufacturer.

I acknowledge that the above points were reviewed with me at the time of delivery.

CUSTOMER'S SIGNATURE

DATE DELIVERED

3. INTRODUCTION

The **Universal Wheel Saw** was designed as an attachment machine for use on numerous host machines, such as skid steer loaders and hydrostatic front end loaders. The information contained in this manual refers only to the Wheel Saw attachment. Information regarding the valves used to control oil flow to the Wheel Saw attachment can be found in the host machine's manual or in the power pac installation manual if the host machine is so equipped.

The information contained within is provided to assist you in preparing, adjusting, maintaining and servicing your machine. More importantly, this manual provides an operating plan for safe and proper use of your machine. Major points of safe operation are detailed in the safety chapter of this manual. Refer to the table of contents for an outline of this manual.

Modern machinery has become more sophisticated and, with that in mind, you must read and understand the contents of the manual **completely** and become familiar with your new machine **before** attempting to operate it.

Terms such as "right" and "left", as used in the manual, are as though the reader is sitting in the host machine's operator's seat and facing the Wheel Saw.

Throughout this manual, information is provided which is set in bold type and introduced by the word **NOTE**. Be sure to read carefully and comply with the message or directive given. Following this information will improve your operating or maintenance efficiency, help you to avoid costly breakdown or unnecessary damage, and extend the life of your machine.

The Manufacturer and the Society of Automotive Engineers have adopted this **SAFETY ALERT SYMBOL** to pinpoint characteristics which, if not properly followed, can create a safety hazard. When you see this symbol in this manual or on the unit itself, you are reminded to **BE ALERT! YOUR SAFETY IS INVOLVED!**



The manufacturer reserves the right to make changes or improvements in the design or construction of any part without the obligation to install such changes on any unit previously delivered.

4. SPECIFICATIONS

UR SERIES WHEEL SAW

| MODEL | STANDARD WHEEL DEPTHS |
|--------------|-----------------------|
| UR-300 | 12 inches (300 mm) |
| UR-450 | 18 inches (450 mm) |
| UR-600 | 24 inches (600 mm) |

Standard wheel widths (all).....2.5 inches (63 mm), 5 inches (126 mm)

Maximum Side Shift Travel (all).....24 inches (610 mm)

| MODEL | Weights |
|---------------|---------------------------------|
| UR-300* | Wheel Saw Assembly.....1435 lbs |
| UR-450* | Wheel Saw Assembly.....1435 lbs |
| UR-600* | Wheel Saw Assembly.....1955 lbs |
| 2.5 x 12..... | Wheel Assembly.....330 lbs |
| 5 x 12..... | Wheel Assembly.....393 lbs |
| 2.5 x 18..... | Wheel Assembly.....435 lbs |
| 5 x 18..... | Wheel Assembly.....520 lbs |
| 2.5 x 24..... | Wheel Assembly.....541 lbs |
| 5 x 24..... | Wheel Assembly.....645 lbs |

* Weights are minus wheel assembly.

5. SAFETY

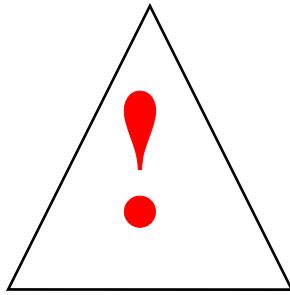

BEFORE YOU ATTEMPT TO OPERATE THIS EQUIPMENT, READ AND STUDY THE FOLLOWING SAFETY INFORMATION. IN ADDITION, MAKE SURE THAT EVERY INDIVIDUAL WHO OPERATES OR WORKS WITH THIS EQUIPMENT IS FAMILIAR WITH THESE SAFETY PRECAUTIONS.

The manufacturer always takes the operator and their safety into consideration when designing machinery. Guards are provided on exposed moving parts for the operator's protection, however, some areas cannot be guarded or shielded in order to assure proper operation. In addition, the operator's manual and decals on the machine itself warn you of further danger and should be read and observed closely.

The **SAFETY ALERT SYMBOL** above means **ATTENTION! BECOME ALERT! YOUR SAFETY IS INVOLVED!** It stresses an attitude of "**HEAD'S UP**" for safety and can be found throughout this operator's manual and on the unit itself.

REMEMBER: The careful operator is the best operator. Most accidents are caused by human error. Certain precautions must be observed to prevent the possibility of injury or damage.

Please read the rules listed below for safe operation **BEFORE** you operate this equipment.

Use of the words **CAUTION, WARNING or DANGER**, herein and on the machine itself, signal three degrees of hazard.

CAUTION is used for general reminders of good safety practices or to direct attention to unsafe practices.

WARNING is used to denote a specific potential hazard.

DANGER is used to denote the most serious specific potential hazard.

5.1 MANDATORY SAFETY SHUTDOWN PROCEDURE

Work of any type on machinery is always more dangerous when the machine is operating. **BEFORE** cleaning, lubricating or servicing this unit, the following **MANDATORY SAFETY SHUTDOWN PROCEDURE** should **ALWAYS** be followed:

1. Move host machine's propulsion control to the neutral position and idle engine down.
2. Shut off Wheel Saw.
3. Position Wheel Saw so that it is completely resting on the ground or floor.
4. Engage the host machine's hand brake.
5. Move the host machine's throttle to the slow idle position, shut the Engine off and remove the ignition key.
6. Relieve hydraulic pressure by moving the Hi-flow and cylinder control levers in both directions.

ONLY when you have taken these precautions can you be sure it is safe to proceed. Failure to follow the above procedure could lead to death or serious bodily injury.

Some diagrams used herein may show Door(s), Guard (s), or Shield (s) open or removed for illustration purposes **ONLY! BE SURE** the all Door (s), Guard (s), or Shield (s) are in their proper position (s) and securely attached **BEFORE** operating the Wheel Saw!

Read and observe **ALL** Safety information and decals on the host machine and Wheel Saw **BEFORE** operating the unit! In addition, familiarize yourself with **ALL** of the Safety Devices and Periodically check that they are functioning properly!

Refer to the **SAFETY** chapter of your host machine's operator's manual and observe **ALL** Safety recommendations set forth in that manual!

BE SURE to raise the Wheel Saw clear of the ground **BEFORE** attempting to traverse it sideways!

CAREFULLY inspect **ALL** hydraulic hoses and connections on a routine basis!

NEVER use your hand; escaping fluid under pressure can cause serious injury!

BE SURE to exercise the above **MANDATORY SAFETY SHUTDOWN PROCEDURE BEFORE** proceeding to do any work on the Wheel Saw!

BE SURE the Wheel Saw is properly placed in the “Service Position” and resting on the ground, **BEFORE** attempting to work on the wheel.

BEFORE transporting the Wheel Saw, **BE SURE** to raise the unit completely clear of the ground and turn it off.

When replacing pics, **BE SURE** to use only a soft or lead headed hammer, and/or Pic tool, when inserting the pics into the holders!

ALWAYS wear Safety Glasses with Side Shields, when striking metal against metal. In addition, it is recommended that a softer (non-chipable) material be used to cushion the blow. Failure to heed could result in serious injury to the eye(s) or other part(s) of the body!

ALWAYS wear proper clothing and covering when working with or on the Rock Saw!

DO NOT attempt to move the Wheel Saw sideways while it is on the ground!

DO NOT attempt to work on the Wheel Saw or host machine with the hydraulics live or under pressure! **BE SURE** to relieve the hydraulic pressure **BEFORE** attempting to disconnect any hoses or **BEFORE** proceeding to remove the Wheel Saw from the hose machine.

DO NOT treat the Wheel Saw like a Bucket, it can be damaged by contact with solid objects as well as upset the stability of the host machine.

DO NOT hit the Pics with a steel hammer as this could cause steel chips to fly, causing injury to the eyes or face.

REMEMBER! It is the owner’s responsibility for communicating information on the safe use and proper operation and maintenance of this machine!

6. OPERATION

6.1 FORWARD

The Wheel Saw must be attached to a host machine equipped to provide the necessary hydraulics and operational controls. As there are many different host machines available, this manual will only deal with the generic operation of the Wheel Saw. Anyone attempting to attach and operate the Wheel Saw must first have the knowledge and skill of operating the host machine's controls. Information regarding the host machine's controls and attaching procedure is found in the host machine's Operator's Manual or from its Authorized Dealer.

6.2 ATTACHING TO AND DETACHING FROM A SKIDSTEER LOADER

During shipment the swingaway control arm that supports the control lever module is folded down to reduce shipping height. Before connecting the attachment to your skidsteer loader, remove the loose 1/4" capscrew from the lower pivot and the 1/4" clevis pin from the upper pivot and raise the arms. Replace the 1/4" capscrew and self-locking nut into the forward-most hole of the lower pivot plate. Tighten bolt to remove any looseness but still allow full travel.

Drive the skidsteer up to the quick tach of the Wheel Saw and connect up. Exercise **THE MANDATORY SAFETY SHUTDOWN PROCEDURE** before proceeding.

After connecting the attachment to the skidsteer loader, check that the swingaway arm is located correctly left to right. Note that the lower pivot bracket has extra bolt holes to allow moving to make left/right location correct.

Put the upper and lower 1/4" clevis pins into correct holes to achieve the best location of the hydraulic control levers.



WARNING! BE SURE THE BOOM ARMS ARE ALL THE WAY DOWN AND THE BUCKET DUMP IS ROLLED ALL THE WAY BACK WHEN ADJUSTING THE ARMS TO AVOID ACCIDENTAL CONTACT WITH THE OPERATOR OR SKIDSTEER CONTROLS!

Attach a set of hydraulic quick couplers compatible with those on the skidsteer to the two main hoses on the Wheel Saw. Make sure that the pressure line from the skidsteer is connected to the "P" Port of the Wheel Saw valve, and the case drain line is connected to the case drain of the skidsteer.

Detaching is the reverse to this process. Make sure the two hoses on the Wheel Saw are connected together to prevent the ingress of dirt.

6.3 PREPARING TO CUT

Check the surface to be cut and ensure the Wheel Saw is properly equipped; asphalt cutting pics for an asphalt surface and concrete cutting pics for a concrete surface.

NOTE: Use of improper equipment may damage Wheel Saw.

Determine the required depth of cut and left to right position of the Wheel Saw as regards the host machine.

When it is safe to do so, start the host machine's engine and ensure that the Wheel Saw wheel is not touching the ground. Turn on the Wheel Saw and check the drum rotation. The pics at bottom of the wheel must be moving in the same direction that the Wheel Saw travels over the material to be cut.

Increase engine RPM, with the wheel turning, you can now make any necessary adjustments to the left and right position of the saw.

REMEMBER! The wheel must be turning to make any hydraulic adjustments. **DO NOT** set the depth of cut until the actual sawing operation begins.

A hydraulic cylinder holds the Wheel Saw in position on the slide frame. Actuate the cylinder to the desired left/right position.

6.4 STARTING THE CUT

Position the Wheel Saw over the desired starting place. With the Wheel Saw turned on, the depth cylinder fully retracted and the host machine's engine at full RPM, slowly lower the saw to the surface to be cut until the weight of the saw is resting on the guide support. Using the depth control, lower the wheel to the desired depth of cut. This must be done slowly to avoid stalling the wheel.

6.5 ADVANCING THE CUT

Advance the Wheel Saw in the direction the wheel pics are traveling in the cut. If the wheel stalls, you have been feeding the wheel into the cut too fast. Back out of the cut until the wheel restarts and then advance again.

DO NOT side shift the Wheel Saw while the wheel is in the cut. The wheel will not cut in a side to side direction. Depth control may be actuated while the wheel is in the cut.

6.6 ENDING THE CUT

Stop advancing the Wheel Saw and raise the Wheel Saw out of the cut by retracting the hydraulic depth control. If you do not wish to start a new cut, idle the host machine engine and turn the Wheel Saw off. **DO NOT** transport the Wheel Saw while it is turned on.

7. DAILY MAINTENANCE

CAUTION: Never attempt to do any maintenance to the Wheel Saw while it is running. Exercise the **MANDATORY SAFETY SHUTDOWN PROCEDURE** before proceeding.

NOTE: Careful attention to the daily maintenance routines will go a long way toward ensuring efficient Wheel Saw operation.

1. At the start of each day, lubricate the cowling pivot point grease fitting. Standard shop gun grease will suffice.
2. Using the correct size wrenches, re-tighten any loose hardware.
3. Inspect for any loose hydraulic fittings or damaged hoses; re-tighten or replace as required.

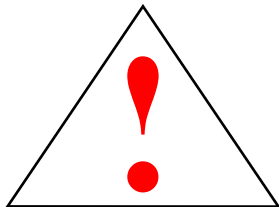

WARNING! NEVER use your hands to check for hydraulic leaks. Escaping fluid under pressure can cause serious injury! If injured by escaping fluid, see a doctor at once. If proper medical attention is

4. At the start of each day, check the lubricant level in the gearbox. Failure to maintain a proper lubrication level will result in breakdowns.
5. At least twice daily check all pics for freedom of rotation and wear. Replace all pics that are not rotating freely or are badly worn. Follow the procedures outlined under Pic Removal and Replacement.

7.1 PIC REMOVAL AND REPLACEMENT

To achieve maximum pic life and optimum performance the pics will require replacement for the following reasons:

1. The surface to be planed is changed from asphalt to concrete or vice versa.
2. They are broken or worn.
3. They are seized in the pic holder and do not rotate freely.
4. Always use pics with a flared base to protect the block.

7.2 REMOVAL

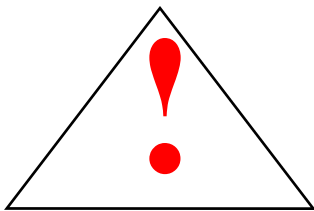

WARNING: ALWAYS wear safety glasses with side shields when striking metal. Failure to heed could result in serious injury to the eyes or other parts of the body!

1. The wheel can be rotated in the forward direction by hand for access to the pic that needs to be replaced.
2. Hold the Pic Removal Tool in one hand and place the Jaws in the groove of the pic, with the offset handle pointing away from the pic holder.
3. Using a lead hammer or rubber-headed mallet, hit the raised pad on the tool until the pic starts to move and continue to tap it out.

NOTE: If the pic does not have a groove, use a Pic Punch and a lead hammer or rubber-headed mallet to drive the pic out of the holder from the back side.

7.3 REPLACEMENT

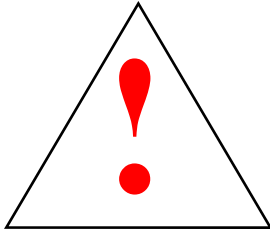

WARNING: ALWAYS wear safety glasses with side shields when striking metal. Failure to head could result in serious injury to the eye (s) or other part (s) of the body!

To replace a pic proceed as follows:

1. With the Pic Removal Tool in one hand, position the new pic in the Jaws of the tool so that the raised pad of the tool is pointing in the same direction as the pic point.
2. Position the stem of the pic in the hole of the pic holder.
3. With a lead hammer or rubber-headed mallet, hit the raised pad of the tool to start the pic into the holder.
4. Then, with one strong blow, strike the tool pad to pop the pic into the hole of the holder.

The pic is properly seated when its shoulder is against the face of the Pic Holder. **BE SURE** to test that the pic rotates freely.

NOTE: If the pic does not have a groove, position the stem of the pic in the hole in the holder and, using a lead hammer or rubber-headed mallet, lightly hammer the point of the pic until the pic is seated in the holder.

7.4 CHANGING A WHEEL

Place the Wheel Saw in a safe position!

1. Remove all of the capscrews holding the side of cowling cover in place.
2. Remove the cowling cover from the Wheel Saw.
3. Remove the capscrews holding the wheel in place on the gearbox shaft.
4. Remove the wheel assembly from the gearbox. This assembly will be tightly fitted, so expect resistance.
5. Check all hardware removed and replace if damaged or broken.
6. Lift the replacement wheel and place in position to align the eight capscrew holes and push the wheel into place. This assembly will be tightly fitted so expect resistance. Once in place, install the eight capscrews, torque to 200 lb ft.
7. Replace the side cowling by aligning the capscrew holes.
8. Replace all capscrews on the side cowling

7.5 ROCK WHEEL GEAR BOX MAINTENANCE

Oil Grade: 85W-140 (Ambient Temp: 40-120 Deg F
75W-90 (Ambient Temp: -5-60Deg F

The oil should be changed after the first 50 hours of use. Additional changes should be Made every 1000 hours or each year - which ever comes first.

THIS PAGE INTENTIONALLY LEFT BLANK

UR SERIES ROCK SAW COMPONENTS

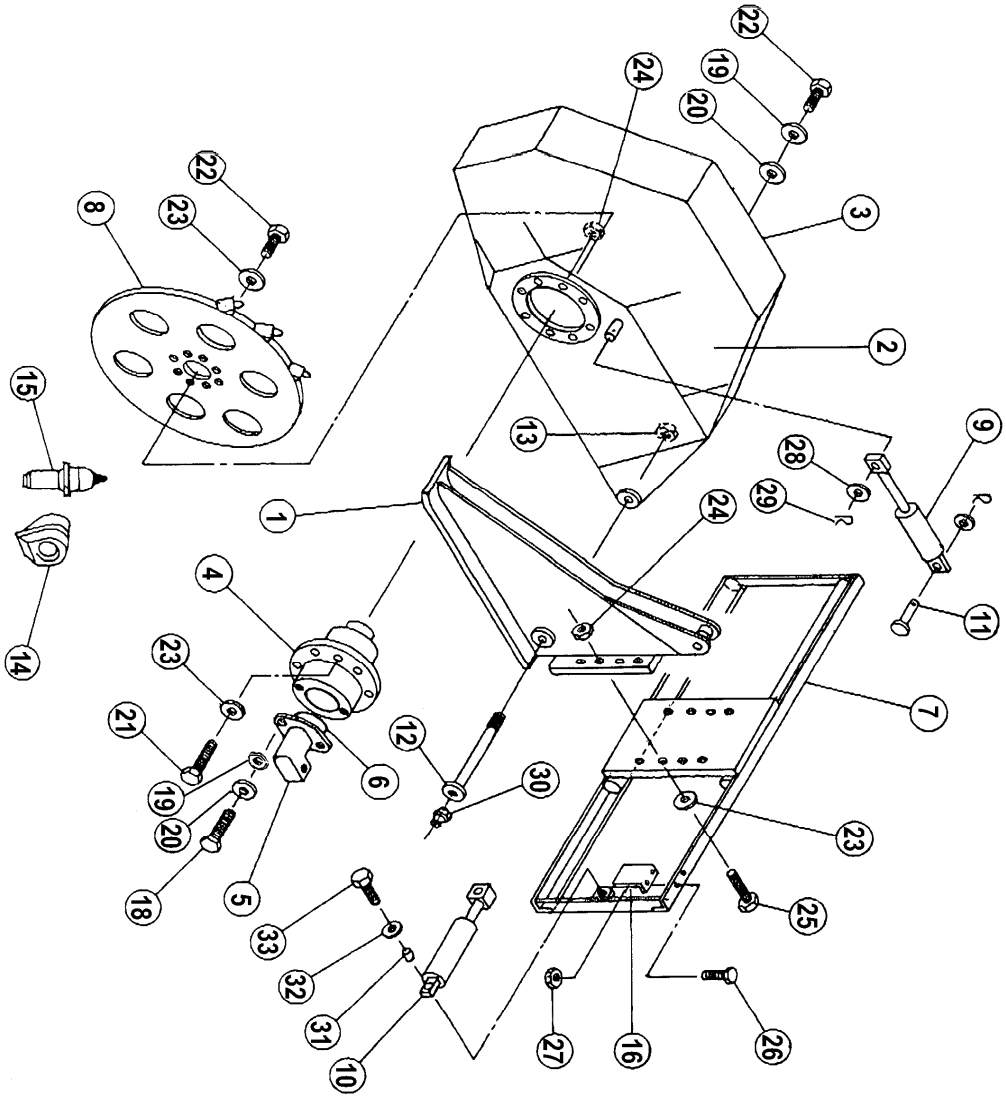

UR SERIES PARTS LIST

| ITEM | P/N | DESCRIPTION | QTY |
|------|------------|----------------------------------|-----|
| 1 | 54355 | Stabilizer Shoe UR 300/450 | 1 |
| 1 | 54338 | Stabilizer Shoe UR 600 | 1 |
| 2 | 54356 | Frame & Cowl Assembly UR 300/450 | 1 |
| 2 | 54339 | Frame & Cowl Assembly UR 600 | 1 |
| 3 | 54357 | Cowl Cover UR 300/450 | 1 |
| 3 | 54340 | Cowl Cover UR 600 | 1 |
| 4 | 55552 | Gear Box 42:1 UR 300/450 | 1 |
| 4 | 55553 | Gear Box 50:1 UR 600 | 1 |
| 5 | 56429 | Motor 2.8 CU IN | 1 |
| 6 | 54342 | "O" Ring Motor/Gear Box | 1 |
| 7 | 56722 | Crossslide Assy | 1 |
| 8 | 54348 | Wheel 2 1/2" x 12 UR 300 | 1 |
| 8 | 54346 | Wheel 2 1/2" x 18 UR 450 | 1 |
| 8 | 54344 | Wheel 2 1/2" x 24 UR 600 | 1 |
| 8 | 54349 | Wheel 5" x 12 UR 300 | 1 |
| 8 | 54347 | Wheel 5" x 18 UR 450 | 1 |
| 8 | 54345 | Wheel 5" x 24 UR 600 | 1 |
| 9 | 54351 | Depth Cylinder UR 300/450 | 1 |
| 9 | 54350 | Depth Cylinder UR 600 UR 600 | 1 |
| 10 | 56745 | Slide Cyl 26" | 1 |
| 11 | 54352 | Depth Cyl Rear Pin | 1 |
| 12 | 54771 | Pivot Pin UR 300/450 | 1 |
| 12 | 54353 | Pivot Pin UR 600 | 1 |
| 13 | 54354 | Nut Pivot Pin | 1 |
| 14 | 40028 | Pic Blocks | AR |
| 15 | 10150 | Pics | AR |
| 16 | 55253 | Valve Bracket Sun | 1 |
| 17 | 350A-12025 | HHCS 12mmx25mm | 18 |
| 18 | 50A-0812 | HHCS 1/2-13x1 1/2" | 2 |
| 19 | 14A-08 | Lock Washer 1/2" | 20 |
| 20 | 14C-08 | Flat Washer 1/2" | 20 |
| 21 | 50B-1032 | HHCS 5/8-11 x 4" GD8 | 8 |
| 22 | 50B-1012 | HHCS 5/5-11 x 1 1/2" GD8 | 8 |
| 23 | 52165 | Hardened Flat Washer 5/8" | 20 |
| 24 | 30C-10 | Nut 5/8" Nylok | 12 |
| 25 | 50B-1020 | HHCS 5/8-11 X 2 1/2" | 2 |
| 26 | 50A-0812 | HHCS 5/16-18 X 1 1/2" | 2 |
| 27 | 30C-05 | Nut 5/16-18 Nylok | 2 |
| 28 | 14C-16 | Washer Flat 1" | 2 |
| 29 | 13L-03 | "R" Pin | 2 |
| 30 | 29A-02 | Grease Fitting | 1 |
| 31 | 57024 | Bushing | 4 |
| 32 | 14C-12 | Waser Flat 3/4" | 2 |
| 33 | 50B-1216 | HHCS 3/4-10 x 2" GD8 | 2 |

FOR GEAR BOX AND MOTOR PARTS SEE PGS 26,27&28

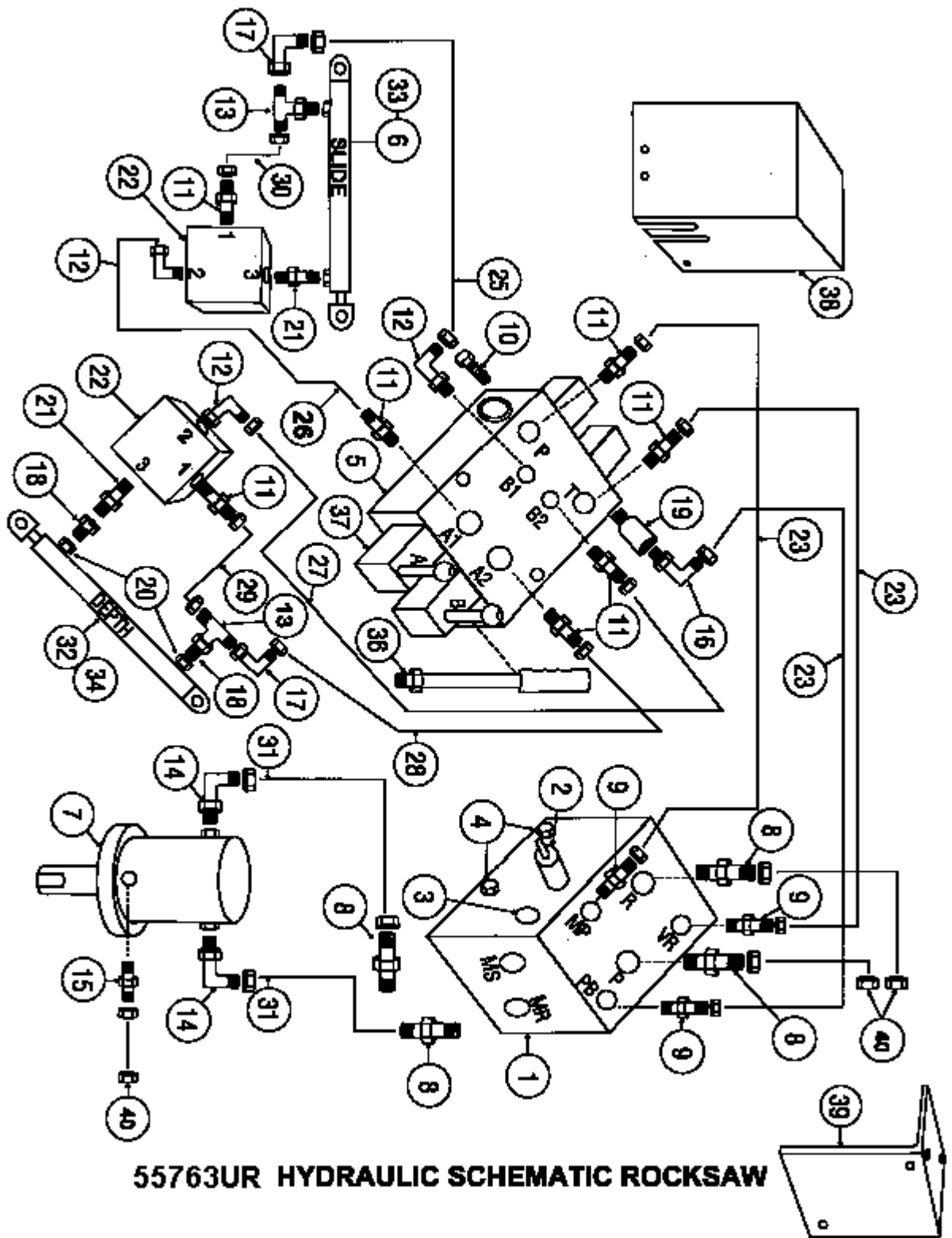

55763UR

HYDRAULIC SCHEMATIC WHEEL SAW

| ITEM | PART # | DESCRIPTION | QTY |
|------|--------------|--------------------------------|-----|
| 1 | 55140 | Valve Complete Sun | 1 |
| 1 | 55229 | Valve Block Only | 1 |
| 2 | 55232 | Cartridge Priority 2GPM | 1 |
| 3 | 55231 | Valve Check PB | 1 |
| 4 | 55230 | Valve Check | 2 |
| 5 | 55228 | Valve BLB 2 SPL | 1 |
| 6 | 54064 | Cylinder Slide | 1 |
| 7 | 54792 | Motor Hyd | 1 |
| 7 | 54864 | Shaft Seal Hyd. Motor | AR |
| 7 | 56358 | Gasket Hyd. Motor | AR |
| 8 | 111E-1212 | Adapter STR JICM/SAEM | 4 |
| 9 | 111E-0404 | Adapter STR JICM/SAEM | 3 |
| 10 | 111HH-08 | Plug SAE | 1 |
| 11 | 111E-0406 | Adapter STR JICM/SAEM | 7 |
| 12 | 111B-0406 | Adapter 90 Degree JICM/SAEM | 3 |
| 13 | 110Y-0404 | Adapter Tee JICM/NPTM | 2 |
| 14 | 111B-1216 | Adapter 90 Degree JICM/SAEM | 2 |
| 15 | 111E-0608 | Adapter STR JICM/SAEM | 1 |
| 16 | 111B-0408 | Adapter 90 Degree JICM/SAEM | 1 |
| 17 | 112B-0404 | Adapter 90 Degree JICM/JICF | 2 |
| 18 | 111S-0406 | Adapter STR NPTF/BSPPM | 2 |
| 19 | 55259 | Sleeve Power Beyond | 1 |
| 20 | 55613 | Seal Bonded BSPP | 2 |
| 21 | 111K-0604 | Adapter STR SAEM/NPTM | 2 |
| 22 | 52981 | Valve Lock | 2 |
| 23 | 55178 | Hose 1/4" x 51" VP-P/VR-T | 2 |
| 24 | 55178 | Hose 1/4" x 51" PB-PB | 1 |
| 25 | 55176 | Hose 1/4" x 63" Slide Base | 1 |
| 26 | 55177 | Hose 1/4" x 78" Slide Rod | 1 |
| 27 | 55273 | Hose 1/4" x 141 Depth Rod | 1 |
| 28 | 55274 | Hose 1/4" x 124 Depth Base | 1 |
| 29 | 54026 | Hose 1/4" x 15 Depth Pilot 450 | 1 |
| 29 | 54114 | Hose 1/4" x 25 Depth Pilot 600 | 1 |
| 30 | 54114 | Hose 1/4" x 25 Slide Pilot | 1 |
| 31 | 55271 | Hose 3/4" x 65 Motor Supply | 2 |
| 32 | 55350 | Cylinder Depth UR 600 | 1 |
| 32 | 55351 | Cylinder Depth UR 450 | 1 |
| 33 | 55033 | Seal Kit Slide Cylinder | AR |
| 34 | 55055 | Seal Kit Depth Cylinder | AR |
| 36 | 55279 | Lever Valve | AR |
| 37 | 55612 | Pivot Box BLB Valve | AR |
| 38 | 55264 | BLB Valve Cover | 1 |
| 39 | 55253 | Sun Valve Bracket | 1 |
| 40 | See Host Kit | | |

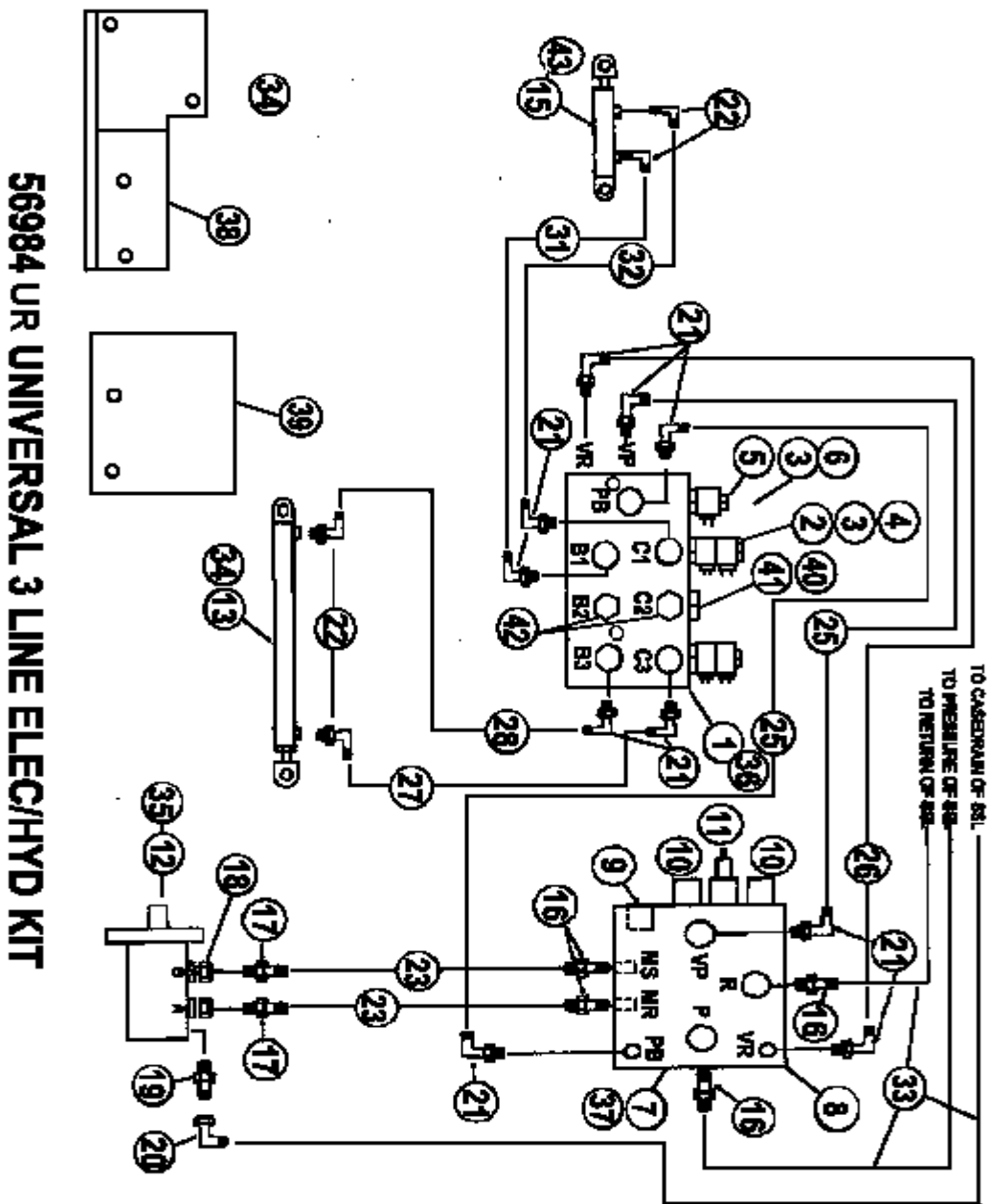

| 56984UR UNIVERSAL 3 LINE HYD KIT PARTS | | | |
|---|------------|--|------------|
| ITEM | P/N | DESCRIPTION | QTY |
| 1 | 56708-2 | Directional Valve 2 Function Incs, 2,3,4,5 & 6 | 1 |
| 2 | 56504 | 4 Way Cartridge Only | 2 |
| 3 | 55611 | Coil & Connector | 5 |
| 4 | 54893 | PO Check Valve | 2 |
| 5 | 56505 | Blocking Valve Cartridge Only | 1 |
| 6 | 56905 | Relief Valve Cartridge Only | 1 |
| 7 | 54140 | Sun Valve Assy Incs, Items 8 thru 11 | 1 |
| 8 | 55229 | Valve Block Only | 1 |
| 9 | 55231 | Check Valve PB | 1 |
| 10 | 55230 | Check Valve Anticav & Return | 2 |
| 11 | 55232 | Priority Valve | 1 |
| 12 | 54329 | Motor Danfoss 800 | 1 |
| 13 | 54064 | Slide Cyl | 1 |
| 15 | 54066 | Tilt Cyl | 1 |
| 16 | 111E-1212 | Adap Str JICM/SAEM | 4 |
| 17 | 40040 | Adap Str JICM/BSPPM | 2 |
| 18 | 42077 | Seal Washer | 2 |
| 19 | 111Q-0604 | Adap Str JICM/BSPPM | 1 |
| 20 | 112B-0606 | Adap 90* JICM/SAEM | 1 |
| 21 | 111B-0404 | Adap 90* JICM/SAEM | 4 |
| 22 | 110R-0404 | Adap 90* JICM/NPTM | 4 |
| 23 | 54723 | Hose 3/4x52" | 2 |
| 24 | 56908 | Tube PB | 1 |
| 25 | 56909 | Tube Valve Pressure | 1 |
| 26 | 56910 | Tube Valve Return | 1 |
| 27 | 55482 | Hose 1/4x 35" Slide Cyl Rod | 1 |
| 28 | 54055 | Hose 1/4x 21" Slide Cyl Base | 1 |
| 31 | 54029 | Hose 1/4x 55" Tilt Cyl Base | 1 |
| 32 | 54028 | Hose 1/4x 51" Tilt Cyl Rod | 1 |
| 33 | | See Host Kit | 1 |
| 34 | 55033 | Seal Kit Hyd Cyl | AR |
| 35 | 52829 | Seal Kit Danfoss Motor | AR |
| 35 | 52677 | Dust Seal Only Danfoss Motor | AR |
| 35 | 52679 | Shaft Seal Only Danfoss Motor | AR |
| 35 | 52680 | O'Ring Only Danfoss Motor | AR |
| 36 | 56911 | Seal Kit 56708-2 Valve | AR |
| 37 | 55277 | Seal Kit 55140 Valve | AR |
| 38 | 56711 | Valve Bracket | 1 |
| 39 | 56712 | Valve Cover | 1 |
| 40 | 56576 | Cavity Plug 3 Way | 1 |
| 41 | 56577 | Cavity Plug 4 Way | 1 |
| 42 | 111H-04 | Port Plug | 2 |
| 43 | 55055 | Seal Kit Depth Cylinder | AR |

**56985UR UNIVERSAL 5 LINE ELEC/HYD KIT
2 FUNCTION**

| ITEM | P/N | DESCRIPTION | QTY |
|-------------|------------|----------------------|------------|
| 1 | 56716 | Valve 6 Way Shuttle | 1 |
| 2 | 52981 | Lock Valve | 1 |
| 3 | 57000 | Valve Bracket | 1 |
| 4 | 57001 | Valve cover | 1 |
| 5 | 111E-0404 | Adapter Str JIC/SAE | 4 |
| 6 | 57038 | Orifice Fitting | 2 |
| 7 | 110R-0404 | Adap 90* JICM/NPTM | 2 |
| 8 | 112B-0404 | Adap 90* JICM/JICF | 2 |
| 9 | 111C-1212 | AdapTee JICM/SAEM | 2 |
| 10 | 112B-1212 | Adap 90* JICM/JICF | 2 |
| 11 | 112A-0404 | Adap 45* JICM/JICF | 4 |
| 12 | 111Q-0604 | Adap Str JICM/BSPP | 1 |
| 13 | 40040 | Adap Str JICM/BSPP | 2 |
| 14 | 54066 | Tilt Cyl | 1 |
| 15 | 54064 | Slide Cyl | 1 |
| 16 | 54329 | Motor Danfoss 800 | 1 |
| 17 | 54029 | Hose 1/4x55" | 1 |
| 18 | 54028 | Hose 1/4x51" | 1 |
| 19 | 54026 | Hose 1/4x15" | 1 |
| 20 | 55482 | Hose 1/4x35" | 1 |
| 21 | 54723 | Hose 3/4x52" | 2 |
| 22 | | See Host Kit | |
| 23 | 55033 | Seal Kit Hyd Cyl | AR |
| 24 | 52829 | Seal Kit Danfoss | AR |
| 24 | 52677 | Dust Seal Only | AR |
| 24 | 52679 | Shaft Seal Only | AR |
| 24 | 52680 | O'Ring Only | AR |
| 25 | 54946 | Seal Kit 52981 Valve | AR |

ROCK WHEEL GEARBOX

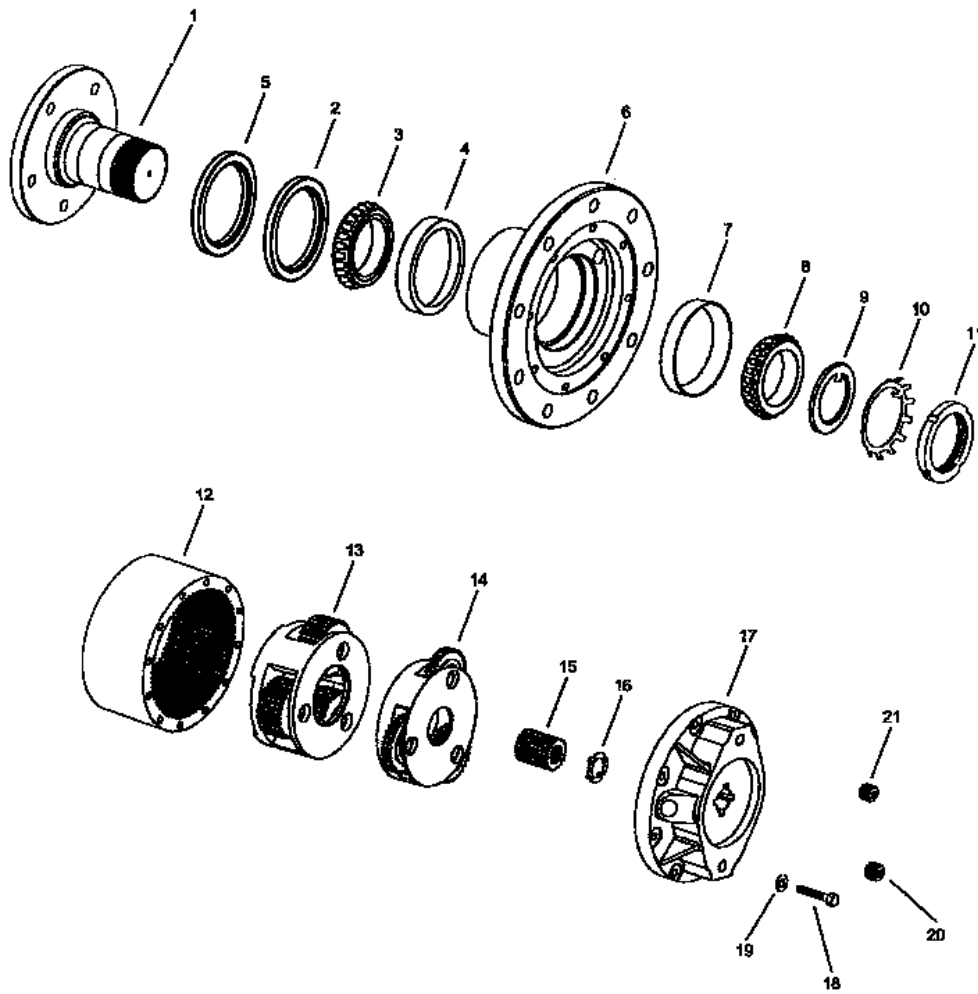

ROCK WHEEL GEARBOX PARTS LIST

42:1 AND 50:1

AUBURN

| <u>ITEM</u> | <u>PART#</u> | <u>DESCRIPTION</u> | <u>QTY</u> |
|-------------|--------------|-----------------------------------|------------|
| 1 | 55881 | Output Spindle | 1 |
| 2 | 54873 | Shaft Seal | 1 |
| 3 | 55378 | Bearing Cone | 1 |
| 4 | 55379 | Bearing Cup | 1 |
| 5 | 55377 | Seal V-Ring 150 | 1 |
| 6 | 55882 | Gearbox Hub | 1 |
| 7 | 55380 | Bearing Cup | 1 |
| 8 | 55381 | Bearing Cone | 1 |
| 9 | 55355 | Washer Large Thrust | 1 |
| 10 | 55361 | Washer Lock | 1 |
| 11 | 55360 | Nut Lock | 1 |
| 12 | 55884 | Ring Gear | 1 |
| 13 | 55890 | Carrier Assy Secondary 42:1 Ratio | 1 |
| 13 | 57845 | Carrier Assy Secondary 50:1 Ratio | 1 |
| 14 | 55889 | Carrier Assy Primary 42:1 Ratio | 1 |
| 14 | 57846 | Carrier Assy Primary 50:1 Ratio | 1 |
| 15 | 55888 | Sun Gear | 1 |
| 16 | 55189 | Thrust Washer | 1 |
| 17 | 55206 | Gearbox Cover | 1 |
| 18 | 55356 | Capscrew | 12 |
| 19 | 55357 | Washer Flat | 12 |
| 20 | 55358 | Plug Magnetic | 1 |
| 21 | 55359 | Plug Plain | 2 |

ROCK WHEEL GEARBOX OMNI

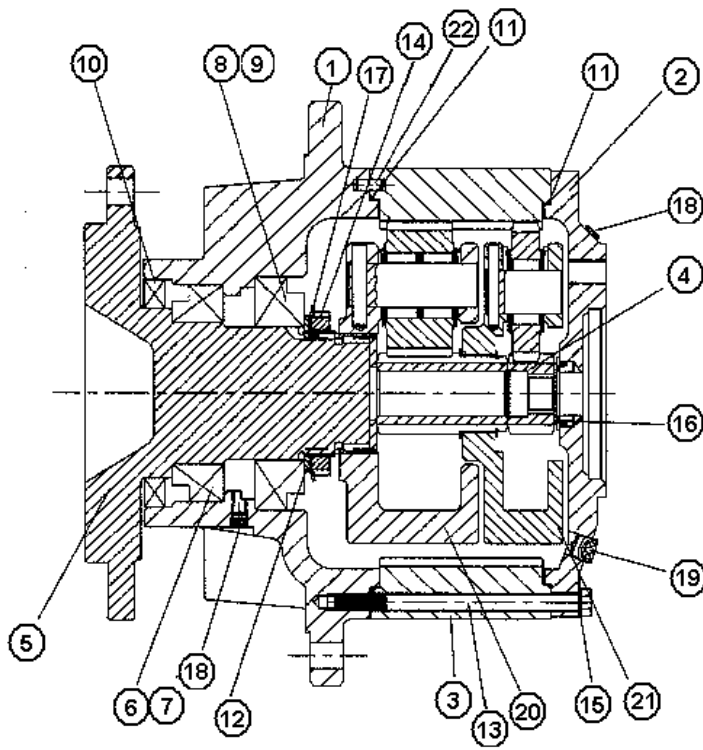

| ROCK WHEEL GEAR BOX PARTS LIST | | | |
|--------------------------------|-------------|-----------------------------|-----|
| OMNI 42:1 & 50:1 | | | |
| ITEM # | PART NUMBER | DESCRIPTION | QTY |
| 1 | 57847 | Housing | 1 |
| 2 | 55206 | Cover Input SAE B | 1 |
| 3 | 57848 | Ring Gear 85 TH | 1 |
| 4 | 57849 | Sun Gear 14 TH | 1 |
| 5 | 57850 | Output Shaft | 1 |
| 6 | 55381 | Bearing Cup | 1 |
| 7 | 55380 | Bearing Cone | 1 |
| 8&9 | 57851 | Bearing Cup & Cone Set | 1 |
| 10 | 54873 | Seal Shaft | 1 |
| 11 | 57852 | O-Ring | 2 |
| 12 | 57853 | Spacer Flat Tongued | 1 |
| 13 | 57854 | HHCS M10x1.5, GD 10.9 | 12 |
| 14 | 57855 | Nut Lock M75x2 | 1 |
| 15 | 57856 | Washer Lock M10 | 12 |
| 16 | 57857 | Washer Thrust Sun | 1 |
| 17 | 57858 | Washer Lock Nut M75 | 1 |
| 18 | 55359 | Plug 1/8-27 NPT | 2 |
| 19 | 57859 | Plug 3/8-18 NPT | 2 |
| 20 | 57860 | Carrier Assy Secondary 42:1 | 1 |
| 20 | 57861 | Carrier Assy Secondary 50:1 | 1 |
| 21 | 57862 | Carrier Assy Primary 42:1 | 1 |
| 21 | 57863 | Carrier Assy Primary 50:1 | 1 |
| 22 | 57864 | Pin | 4 |
| | | | |
| | | | |
| | | | |

SAUER DANFOSS MOTOR

56429

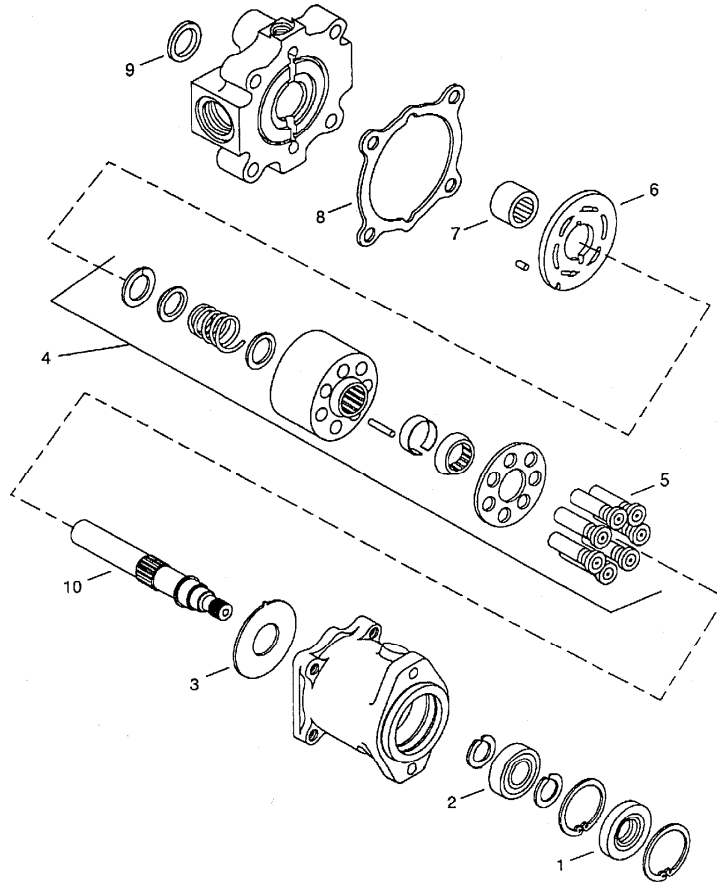

| Item | P/N | Desc. | Qty |
|------|-------|------------------|-----|
| 1 | 54864 | Motor Shaft Seal | 1 |
| 8 | 56358 | Motor Gasket | 1 |

All other parts not serviced separately